



MINERVA[®] MX

MX-Net Inter-Controller Network

Features:

- Allows MX Fire Controllers to be “seamlessly” networked together
- True peer-to-peer communications; no host or master controller required
- Highly resilient, node failure open and short circuit does not affect remaining network
- Designed to comply with BS5839:Pt. 4: 1998
- Up to 99 controllers may be used on the network
- Wide range of cable topography supported
- Network can use standard 1.5mm MICC cable
- Easy to install and programme
- Simple to operate

MX Net: Inter-controller Network

The use of the MX Net allows the fragmentation of a number of fire controllers to be drawn into a network system. Because every installation is different, MX Net has been designed to be highly flexible, allowing for a wide range of different systems applications.

With a large network system the amount of data and information passing between fire controllers can become high during an emergency condition. MX Net communication protocol has been specifically designed with this in mind and ensures that each event message passed around the network is acknowledged by the receiving controller in the fastest possible time.

MINERVA[®] MX

Operation

The network is totally flexible and enables from 2 to 99 fire controllers to be seamlessly linked together, providing a system capability of up to 23,760 fire zones with 99,000 detection addresses, and over 49,000 digital I/O points.

System Overview

The MX Net communications network comprises a collection of network interface modules and peripheral equipment that together form a fault resistant, and flexible peer-to-peer network for the MX Digital addressable fire systems controllers.

With MX Net, each MX Fire Controller on the network permits an operator to interrogate and control any other MX Fire Controller on the network. For extended interrogation and control, MX Net allows for up to a maximum of five nodes on the network to be configured either as Master operating stations or MX Graph, Graphical user interfaces (refer to datasheet PSF 125).

Master operating stations use the standard MX Fire Controller hardware. In this application, the controller changes its personality, and enables additional information from each controller on the network to be displayed.

MX Graph is a P.C. WindowsNTTM based system, utilising the latest in multi-tasking software. This provides a costs effective and simple to use picture of the complete network.

As events happen, MX Graph will display the status of the detectors, fire doors, smoke fans etc. The system automatically presents events in pre-determined colour coded priority order, enabling a fast operator response to an emergency condition.

The powerful zoom-in feature on geographical maps enables the event location on the site or building to be pinpointed. Automatic procedures highlight to the operator, guidance on what action should be taken.

Mode of Operation

MX Net employs a token passing communications protocol that treats each node on the network equally. Loss of one or more nodes does not affect the operation of the remainder of the network.

Data is regenerated at each node in the network enabling maximum distance between nodes. In the event of a short open circuit on the network between any two nodes, isolation will automatically occur and the network will re-configure communications and continue to allow communication between all nodes physically connected.

Unlike some computer networks, MX Net offers a high level of system integrity, allowing safety critical actions to be passed across the network from one MX Fire Controller to another. This very high level of system integrity enables MX Net to meet the requirements of BS5839:Pt. 4: 1988.

TLI-800 Network PCB

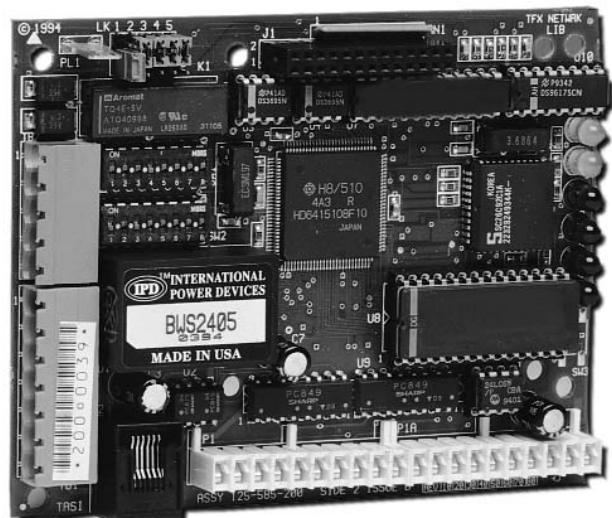

MINERVA[®] MX

Information Exchange

When a MX fire controller is connected to MX Net, each controller maintains full stand-alone capability, whilst also operating as part of a larger system. Once the MX Fire Controller is connected to the network, the following capabilities are provided.

- Peer Event Exchange:- MX controllers send and receive change-of-state (event) information via the network to distribute and co-ordinate system control.
- Event/Action:- MX Controllers support a unique programming capability known as "Event action". This facility is used extensively for the stand-alone fire controller as well as network applications.
- Peer Event display:- MX fire controllers on MX Net can optionally display events received from other MX Fire Controllers. If required, the network can be configured so that only certain events/actions are passed between certain controllers setting up in effect sub-networks.

The following information is provided on the 16 x 40 character L.C.D. at each MX Controller programmed to display peer events.

- Identification of controller originating the event.
- Event type ie ("Fire alarm, Fault, Clear" etc.).
- Identification of the zone to which the point is assigned.
- Identification of the point that changed state.
- Network Zone Links:- As part of peer to peer exchange, a feature called "Network Zone Links" is available to link a fire zone of one controller to a zone of a second controller. Once linked in this manner, devices assigned to both zones operate as though they were all assigned to the same zone.
- Sectors:- This feature is available for creating groups of related fire zones. MX Net will support up to 80 sectors into which any one, any set or all MX Zones can be assigned. With this facility, Group Actions can be defined to operate on sections instead of zones, enabling one action to control outputs of multiple selected zones. Typical application for sectors, would be to turn on evacuate sounders, shut all fire doors etc.

MX Net Wiring Topologies

MX Net supports a wide variety of communications media and wiring typologies. This system's flexibility means that MX Net can be applied to most existing site layouts and wiring schemes.

Bus/Spur

MX Net may be wired as a Bus/Spur circuit, using any of the wiring type listed over, or using a mixture of wiring type. Using the bus circuit will reduce the level of system integrity a cable open or short circuit between network nodes could not be automatically re-configured.

BusTopology

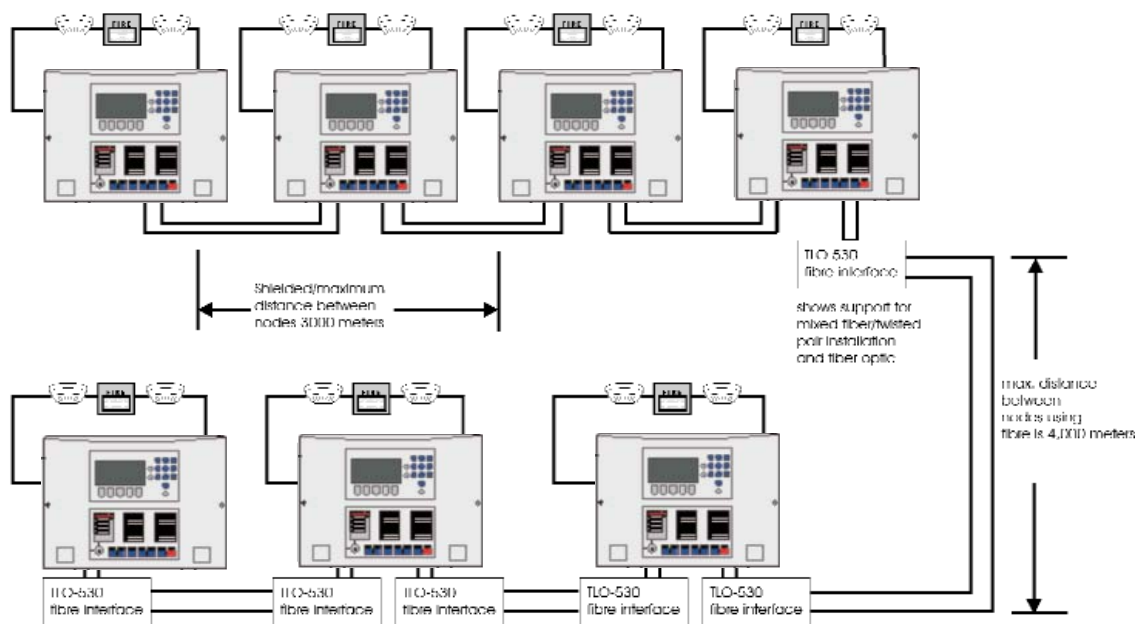

MINERVA[®] MX

MX Net Wiring

Mineral insulated copper clad (MICC)

RS 485 electrical signalling around the network using standard MICC cable enables up to 1000 meter distance to be achieved between each node on the network. Use of MICC cable that complies with BS6207 allows the network to be used to signal events such as "FIRE EVACUATE" over the network in accordance with BS5839: Pt. 1: 1988.

Shields/Twisted Pair

The maximum distance between nodes of a circuit is 3000 metres using shielded twisted pair cable. Examples are Belden 9460 or 9574 or using cables with the parameters below:-

Fibre Optics

Fibre optics can also be supported on the MX Net system, using either type 62.5/125 or 50/125 multi-mode fibres between nodes on the network. Use of fibre permits a maximum distance between nodes of 4000 metres in either bus or ring topology.

Ring

MX Net wired as ring, enables the network to be fully operational even with an open or short circuit fault between two network nodes. Any of the wiring types can be used in the network ring topography, however if the network is to be installed to BS5839: Pt. 1 and Pt. 4 :1988 with the requirement for prolonged operation during a fire it is recommended that mineral-insulated copper-clad (MICC) or other suitable cable to BS6207 is used.

Ring Topology

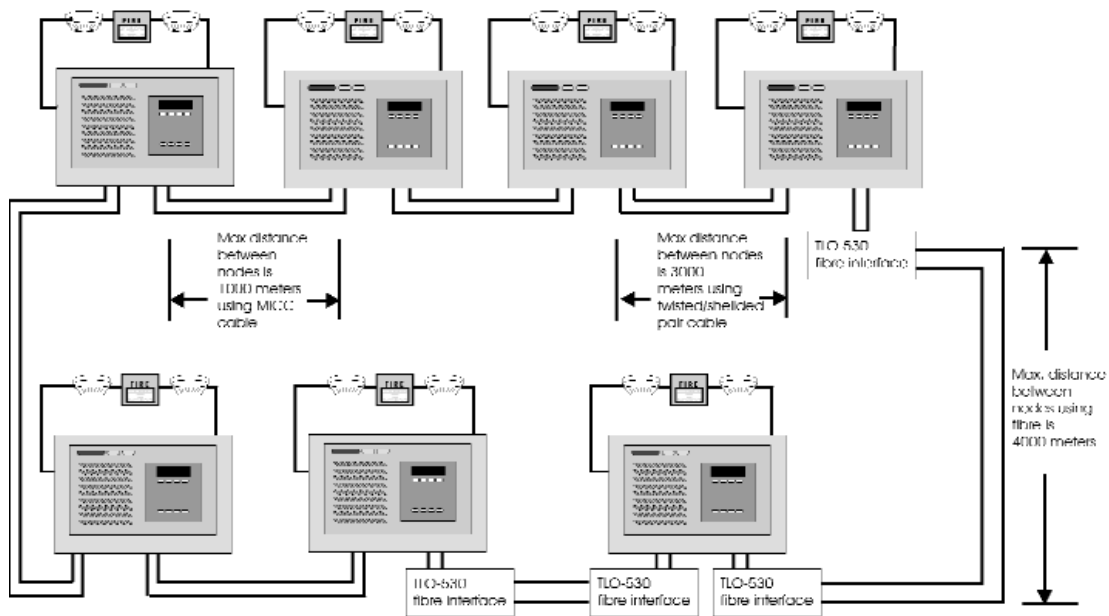

CABLE PARAMETERS
Maximum resistance = 75ohms (all baud rates)

Maximum wire-to-wire capacitance	
BAUD RATE	CAPACITANCE
38400	0.3uF
19200	0.6uF
9600	1.2uF
2400	1.2uF
1200	1.2uF

MINERVA[®] MX

Distributed Systems Network

MX Net provides the gateway to allow a number of MX fire controllers to be “seamlessly” networked together, from a simple two controller configuration to the most complex multi user distributed installation. MX Net has been designed for use in high rise commercial and residential buildings, and is equally suitable for campus style environments such as universities, hospitals and industrial parks.

Unlike other Fire Companies that use off the shelf computer type networks for networking fire controllers, MX Net has been specifically designed with high system integrity in mind allowing the network to be installed in accordance with BS 5839: Pt.1 :1988.

Why Choose MX Net?

- Network, Fire Controller and detection devices all designed and manufactured by Tyco Safety Products, eliminating split responsibility for compatibility.
- Uniquely powerful “CONSYS” event action software programming extended from a single MX Fire Controller, across the MX Net network.
- Highly resilient to short/open circuit faults.
- Peer to peer event exchange.
- Data regenerated at each node.

Typical Applications for MX Net Include:-

- Hotels
- University Campus
- Shopping Centres
- Hospitals
- Sports Centre Complexes
- Office Blocks



- Department Stores
- Museums
- Historic Houses
- Industrial Parks
- Airports
- Cruise Liners

SPECIFICATIONS

TLI 800 Network PCB

Mechanical

Dimension (mm):	116L x 90W x 15D
Weight (Kg):	0.15
Housing:	The TLI800 Network P.C.B. is installed directly onto the MX CPU P.C.B.

Electrical

Supply Voltage:	24vdc
Quiescent Current:	150 mA
Alarm Current:	150 mA
Network Connections:	2 x RS 485
Network diagnostic:	7 x on board LED's / RS232 port for system analysis and fault finding
Cable Type:	2 Core MICC, Shielded/Twisted pair or Fibre Optic*
Network Connections:	12 way 1.5mm Screw terminal block

Network Parameters

Number of nodes:	99(MAX)
Distance between nodes:	1000 to 4000 metres (depends upon cable type)
Communications type:	RS485
Baud Rate:	Configured from 1200 to 38.4K
Transport Type:	Token passing, non-collision protocol

Environmental

Operating Temp Range:	-10°C to + 55°C
Storage Temp:	-10°C to + 70°C
Relative Humidity:	95% (100% intermittent)

TLO-530 Fibre Optic Interface

* When using Fibre Optic Cable, MX Net requires two fibre optic cables between any two nodes on the controllers, one to transmit data and one to receive data. The TLO-530 fibre optic Modem Module converts RS485 digital data current pulses from the TLI-800 Network P.C.B. to light pulses. The light pulses are then carried over fiber optic cabling to a TLO-530 where the pulses are converted back to RS-485 digital data current pulses.

TLD-530 Line Driver Interface

The TLD-530 line driver enables a dedicated telephone circuit of up to 3000 metres to be used to connect two nodes on the network.